

InterLock 681

Datasheet

Rev. 00 • Update 03/2022



DESCRIPTION

1. **Monobloc frame in painted steel**, 3 mm thick, reinforced with a internal steel structure.
2. **Manual opening doors** made of painted steel and laminated clear glass BR3S P6B.
3. **Lateral panels** made of painted steel and laminated clear glass BR2-P6B.
4. **Metal floor** of 25 mm thick for installation on a finished floor.
5. **Control board unit & motorisation:**
 - Programmable electronic board
 - Input / Output interface board
 - Remote console for operating mode adjustment
 - Voice messages device
 - Back-up batteries (2) ensuring 100 cycles in case of power failure
 - Electro-mechanical lock of the obstacles (with programmable unlocking in case of power failure)
 - Safety cells for reopening in case a presence is detected in front of the obstacles (anti-pinch safety)
6. **Spotlights** for the passageway lighting.
7. **Function pictograms:** LED displays indicating the status of the security booth.
8. **Presence sensors and single person device.**
9. **Push buttons** for emergency opening and intercom.

The **InterLock series booths** are designed to provide high-security access control and management of pedestrian flow.

Designed for conventional entrances the **InterLock 681** security booth features clean lines, bringing the high standards anti-robbery doors and the simplicity of a manual door together.

It is offered with right or left-handed doors and **passage width of either 700 mm** (a smaller solution which allows the addition of some interesting extra features to the standard set-up, such as a metal detector) for an **external width of 1050 mm**.

The security booth **IL 681** is a sheet steel monoblock, customizable in RAL colors or with a gloss finish. Although with its rectangular shape and classic manual opening it is a minimalistic door, due to its safety and simplicity this security portal is a very popular solution.



CONFIGURATIONS

1. RAL7035 Light Grey (by default) - RAL9011 Black - RAL9010 White - RAL8019 dark brown.
2. Profile position for wall connection:
 - entry / outside side.
 - middle position (by default).
 - exit / inside.
3. In the event of a power failure:
 - All doors can be opened manually
 - Exit door (secured side) remains locked
Entry door (non-secured side) can be open manually
 - all doors remain locked
4. Integration of card reader, intercom and/or push button at the entry and/or exit of the booth.
5. Choice of the language of voice message and control consol.

SURFACE TREATMENT

All the mechanical parts are treated against corrosion by electro zinc, according to RoHS norms.

STANDARD TECHNICAL CHARACTERISTICS

Power supply	220VAC, 50/60 Hz, 10 A + ground
Consumption	200 W
Ambient operating temperature	-10° to +55°C
Battery backup	Batteries to allow operation in case of power failure
Passages	6 passages at the minute in entrance and exit
Dimensions	Overall dimensions (mm): Height: 2300 Width: 1050 Depth: 1050 Passage dimensions (mm): Height: 2034 Width: 700
Weight	700 Kg
Relative ambient humidity	85%, without condensation
MCBF (Mean cycles between failures)	1,000,000 cycles, in compliance with recommended maintenance
MTTR (Mean time to repair)	2 hours
	Complies with European standards

WORKS TO BE PROVIDED BY THE CUSTOMER

- Fixing on the floor.
- Power supply.
- Connection between booth and access control devise.

Note: Follow the installation plan.

OPTIONS

1. Metal plate cover on the top of the booth.
2. Microswitch contact under the cover for anti infraction alarm.
3. Non standard RAL color.
4. Smooth RAL color.
5. Brushed stainless steel 304 L.
6. Special support for installation on technical floor (Hmin100mm/ Hmax400mm).
7. Support for reader (card, biometric...), placed inside the booth.
8. Support for readers (width > 4 cms) fixed on the external (entrance) side on the internal (exit) side of the booth metal structure.
9. Mechanical locker for metal objects with 10 drawers.
10. Radar for automatic door opening (entry / exit way).
11. Colour video camera inside of the booth.
12. Auxiliary control console (in connection with the standard control console).
13. Remote special console with extra buttons (3 rows of buttons).
14. 12V 7 Ah batteries (2).
15. Electronic card for the transmission in serial line of the weight detected inside the booth.
16. Converter RS485 to LAN for network consoles (each).
17. Service kit (cable, software, key...).
18. Top canopy with different height.
19. Virtual Console for remote monitoring (software & PC).

SPECIFIC OPTIONS

1. Metal detector & Left object control devices entry way only.
2. Lateral glass BR3S P6B (left panel / right panel)
3. Mobile glasses (manual doors) and lateral glasses BR4S P8B.
4. Rain protection / product with weight detection + 50 mm height of the product.
5. Heating of the canopy for outside front installation.
6. Frosted glass.

Note: For restrictions on options, please contact us.

STANDARD DIMENSIONS (MM)

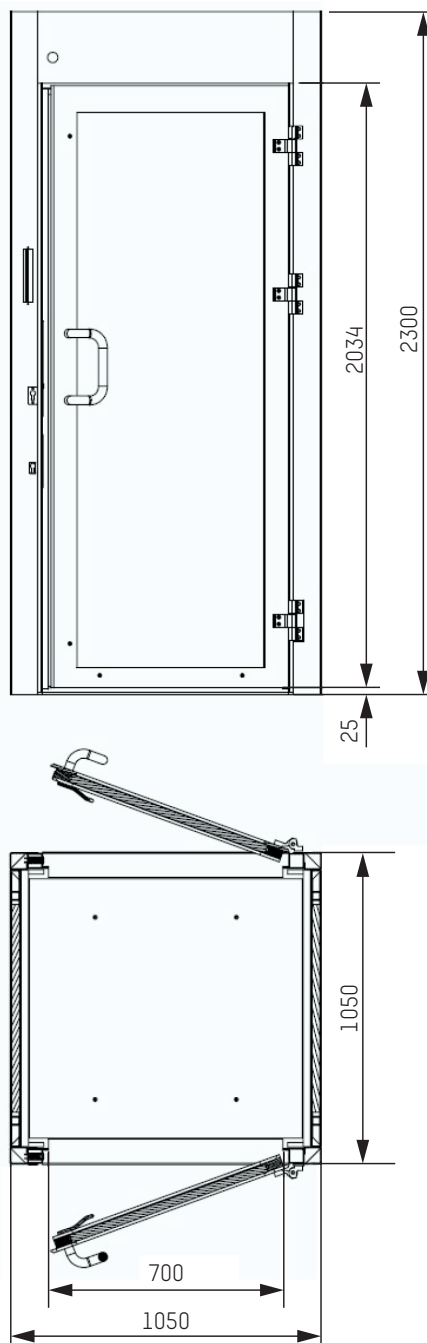

Headquarters
Avenue Mercator, 5
1300 Wavre - Belgium

✉ helpdesk.as@automatic-systems.com

☎ +32.(0)10.23.02.11

🌐 www.automatic-systems.com



IL 681-FT-EN-00